



CINGO e-POWER

provisional documentation



PERFORMANCE AND FEATURES

CINGO e-POWER

PERFORMANCE

Capacity:	600 kg
Maximum speed:	2 modes: ECO and POWER 3 – 5 km/h
Battery autonomy:	4 h
Recharge time:	up to a maximum of 3 hours
Maximum longitudinal gradient:	35%
Maximum cross slope:	20%
Track:	fixed

TRANSMISSION AND HYDRAULIC SYSTEM

Power supply:	100% electric
Battery:	Lithium 48 V / 7500 Wh
Auxiliary circuit pump:	1,7 cc
Auxiliary circuit oil flow rate:	5 l/min
Auxiliary service lines:	2 auxiliary hydraulic functions
Oil type:	biodegradable hydraulic oil
Multifunction tracked carrier:	Yes
Accessories:	on-board battery charger 240 V / 16 A - USB socket - 2-pin socket
Options on request:	charging cable in 2 single-phase mode

WEIGHT AND DIMENSIONS

Machine weight:	500 kg
Width:	753 mm
Length:	1560 mm
Maximum height:	1200 mm

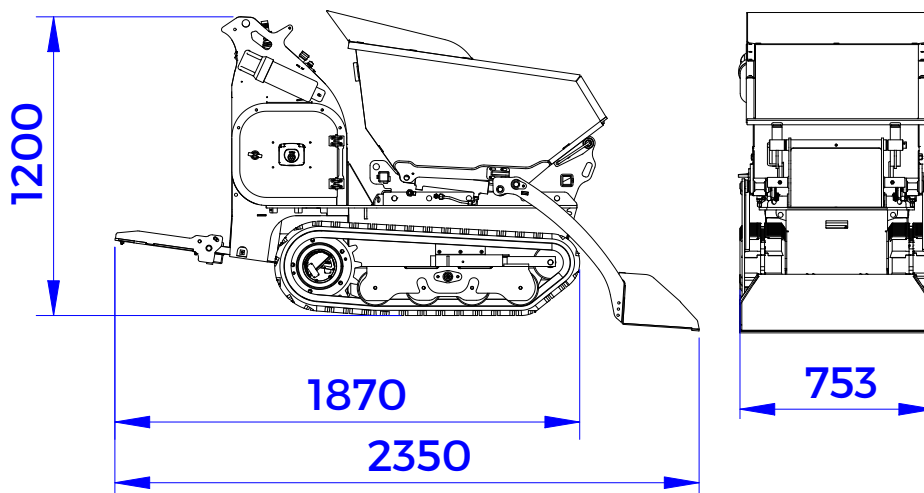
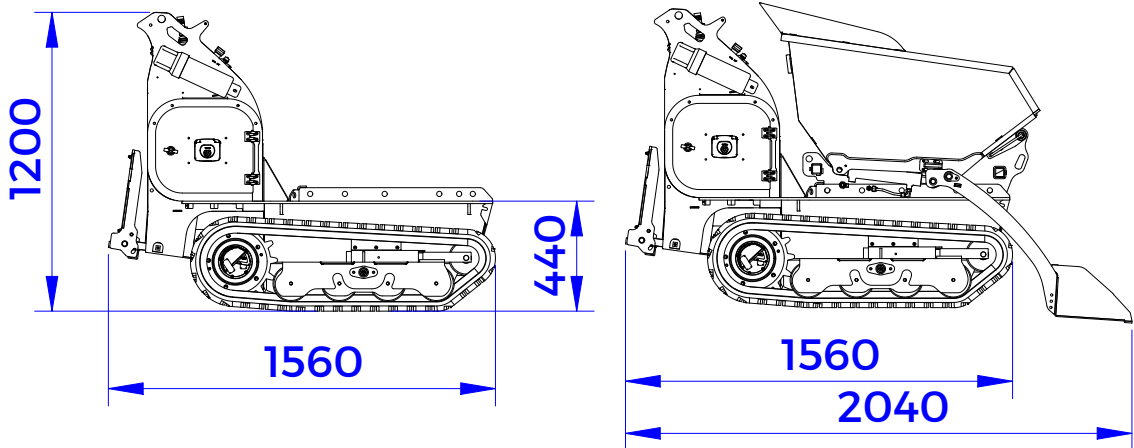



Hydraulic quick coupler sockets for the two hydraulic functions



Easy and quick battery charging



Frame for installing attachments for quick and easy replacement of available accessories



Ergonomic and intuitive driver's seat



MERLO S.P.A.

Via Nazionale, 9
12010 S. Defendente di Cervasca
(Cuneo) Italy
Tel. +39 0171614111
Fax +39 0171684101

info@merlo.com
www.merlo.com

Data, characteristics and illustrations contained in this document are indicative and not binding. Merlo Spa pursues a policy of continuous research and development, therefore, our products may have different characteristics from those described or may undergo changes without any prior notice. The products shown may include optional equipment

Your Merlo dealer

