



CINGO M8.3 EVO



MERLO

PERFORMANCE AND FEATURES

CINGO M8.3EVO Multifunction

PERFORMANCE

Capacity:	800 kg
Engine:	Kubota Diesel Z602 – 12.5 kW / 17 HP – 2 cylinders
Starting:	Electrical
Engine cooling:	Liquid-type
Maximum speed:	4 km/h
Track:	Fixed
Maximum longitudinal gradient:	35%
Maximum cross slope:	20%

TRANSMISSION AND HYDRAULIC SYSTEM

Transmission:	Hydrostatic-type, with axial piston pumps in tandem with planetary gearmotors
Transmission pumps:	2 x 38 litres/min
Drive levers:	Hydraulic servo controls
Service pump:	8 + 2.5 cc (double pump)
Auxiliary circuit oil flow rate:	27 + 8 l/min
Auxiliary service lines:	1 auxiliary service line (in and out) with hook to supply fluid continuously to the 1-lever distributor 3 auxiliary service lines (in and out) of which one with hook to supply fluid continuously to the 4-lever distributor
Auxiliary circuit max. pressure:	180 bar
Multifunction (Merlo patent):	Yes

WEIGHT AND DIMENSIONS

Machine weight:	510 kg
Width:	800 mm
Length:	1,650 mm (with folded operator platform)
Maximum height:	1,124 mm

- not available. ● standard. ○ optional.

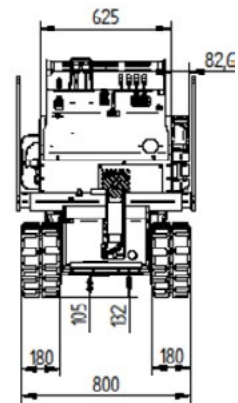
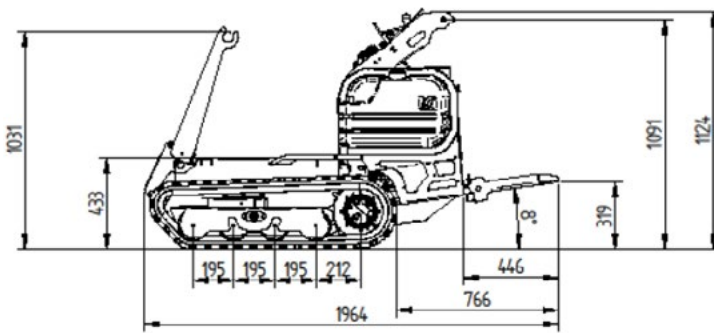

Data, characteristics and illustrations contained in this document are indicative and not binding. Merlo Spa pursues a policy of continuous research and development, therefore, our products may have different characteristics from those described or may undergo changes without any prior notice. The products shown may include optional equipment

MERLO S.P.A.
Via Nazionale, 9
12010 S. Defendente di Cervasca
(Cuneo) Italy
Tel. +39 0171614111
Fax +39 0171684101

info@merlo.com
www.merlo.com

Your Merlo dealer

